



**620 Magnolia Avenue
Suite B
Ontario, CA 91762
(909) 923-1973**

WIRING SCHEMATICS

CLUB CAR PRECEDENT GOLF CAR

REVISION: G

NOTICE: This drawing is the property of H Performance Electric Vehicle Systems Inc., and/or its subsidiaries and affiliates (individually and collectively "HPEVS"), and contains highly proprietary, confidential, and trade secret information of HPEVS. The recipient of this drawing agrees (a) to use the information contained herein for the purpose for which it was furnished by HPEVS (b) to return this drawing upon HPEVS request. This notice shall appear on any complete or partial reproduction of this drawing.

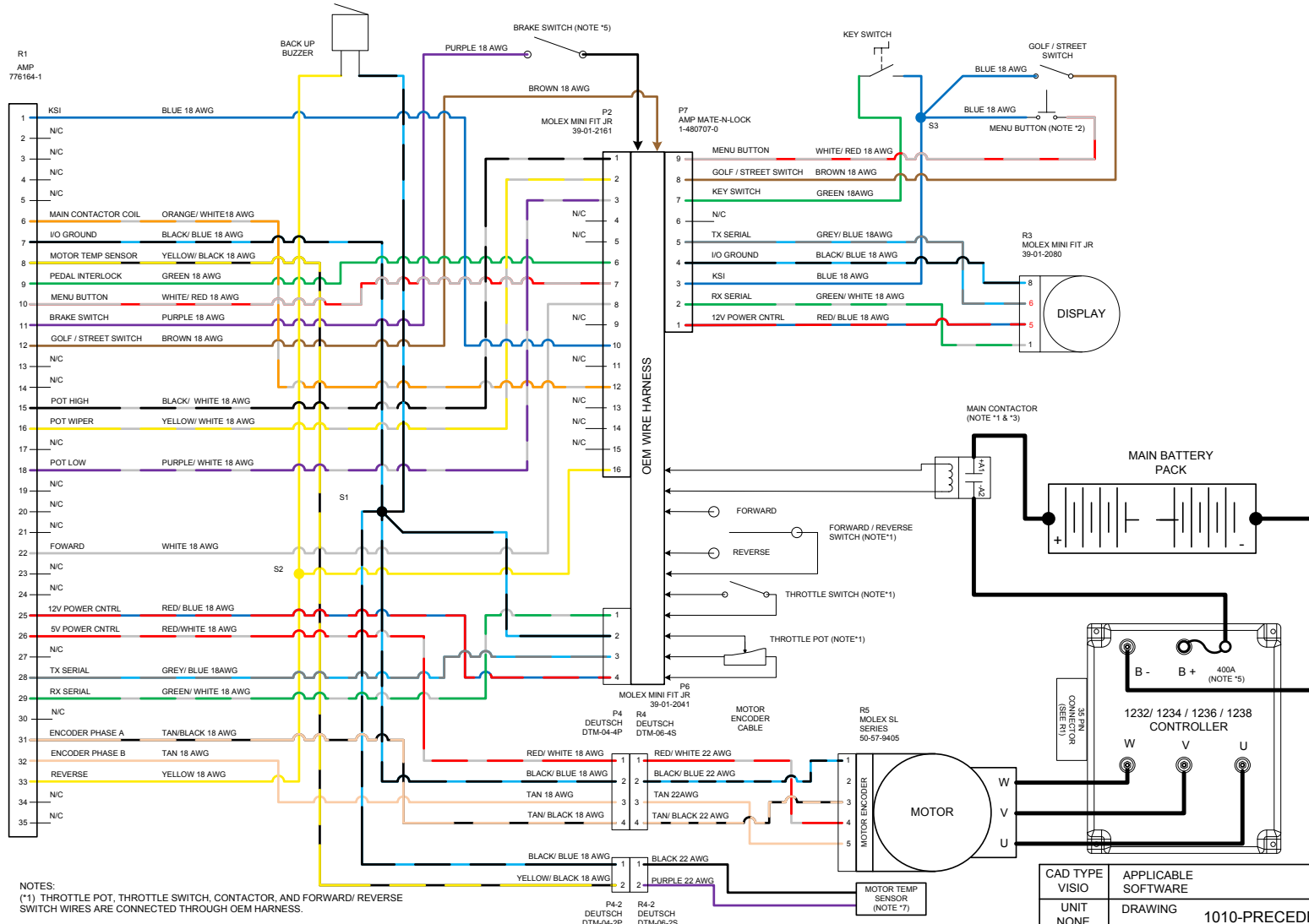

NOTES:
 (*1) THROTTLE POT, THROTTLE SWITCH, CONTACTOR, AND FORWARD/ REVERSE SWITCH WIRES ARE CONNECTED THROUGH OEM HARNESS.
 (*2) MENU BUTTON IS OPTIONAL USE WITH DISPLAY. NORMALLY OPEN; MOMENTARY
 (*3) REMOVE ANY DIODES OR RESISTOR FROM MAIN CONTACTOR.
 (*4) USE 400A FUSE IN 650 SYSTEM. USE 300A FUSE IN 350 SYSTEM.
 (*5) NORMALLY OPEN. CONTACTS MUST BE CLOSED WHEN BRAKE PEDAL IS PRESSED.
 (*6) MOTOR TEMP SENSOR NOT USED FOR GOLF CART APPLICATION.

CAD TYPE	VISIO	APPLICABLE SOFTWARE
UNIT NONE	DRAWING	1010-PRECEDENT
DRW SIZE A	TITLE	
DATE	PRECEDENT GOLF CAR SCHEMATICS	
1/10/11		
SUPPLIER PART	HW-SET-HPG	
SCALE	SHEET 1 OF 1	REVISION G HPEVS
1:1		